

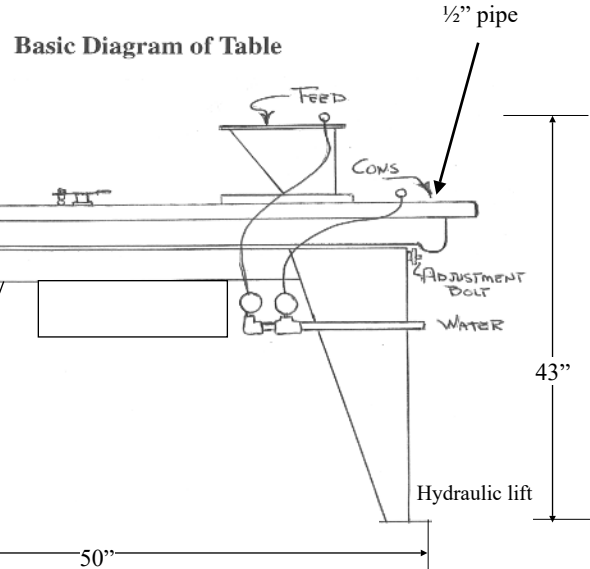

315 E. Railroad Ave.  
Plains, MT 59859  
Tel: 406.826.9330

**Micron Mill Wave Table**  
Standard control leg mounted  
Price \$15,295.00 USD

**M7/M8/M9 Model**



Production Rate	Water requirements	Power 60 cycle (M7) (M9)	Power 50 cycle (M8)	Base foot print	Length table top	Width table top	Height	Weight	Foundation
600-2500 lbs wet slurry feed per hour depending on material run  80-99% recovery 20 mesh - 5 microns  Separates by specific gravity	3-8 GPM (can be recycled), 2 adjustable spray bars  Supplied with flex hoses that attach to standard 1/2" hose lines	1/2 HP variable speed totally enclosed motor, 1760 RPM, 110-220V 600 watts, 1.9 amps, 3 phase, IP55, temperature tolerance class F  <u>Variable speed control</u> 120-240V, 3.6 amps, 50/60 Hz, single phase, NEMA 4X, LED display, Adjustable acceleration/deceleration time 0.3-20 seconds	1/2 HP variable speed totally enclosed motor, 1760 RPM, 220V 600 watts, 1.9 amps, 3 phase, IP55, temperature tolerance class F  <u>Variable speed control</u> 240V, 3.6 amps, 50/60 Hz, single phase, NEMA 4X, LED display, Adjustable acceleration/deceleration time 0.3-20 seconds	50" x 26 1/2"  Holes on center 47" x 24" for securing to concrete floor  Leveling risers included for 2 legs	61"	32"	43"  Including feed trough with screen  Working height 33" (ground to table top)  Built-in hydraulic jack lift	412 lbs	Minimum 5' x 3' 4" slab  Ideally 12' x 9" for working space